

ZE-8570-8580

**Electronic Single Needle Zigzag Lock Stitcher
With Under- Edge Trimmer**
**Electronic Single Needle Zigzag Lock Stitcher
With Thread Trimmer And
Under- Edge Trimmer**



	ZE-8570		ZE-8580		
	0	A	3	4	9
Thread trimmer	—	—	Solenoid		
Upper thread feeding device	—	—	Solenoid		
Back tack/condense device *1	—	Solenoid			
Thread wiper	—	—	—	Solenoid	
Automatic presser foot lifter	—	—	—	—	Solenoid

	ZE-8570		ZE-8580	
	General (foundation)			
Use	For light-weight materials-medium-weight materials			
Maximum stitch length	2.5mm			
Max. sewing speed	5,000rpm*2 (depends on material and process conditions)			
Sewing pattern	14 patterns of eight types built-in (Up to 99 different types of custom-made patterns can be added*3)			
Max. zigzag width	8mm (Factory default 4.5mm)			
Thread take-up lever	Rotary thread take-up			
Needle bar stroke	33.3mm			
Feed dog height	1.5mm			
Presser foot height	Presser bar lifter	4mm		
	Knee lifter	8mm		
	Automatic	5mm		
Presser foot pressure	20-60N*4			
Trimming margin	1.5-9.5mm*5			
Needle	Schmets SY 1965 Nm70/10			
Motor	Three-phase 400 W induction motor			
Power supply	Single-phase	110V, 220V, 230V, 240V		
	3-phase	220V, 380V, 400V, 415V		
	Maximum electric power consumption: 600 VA			

*1 ... Used for sewing condensed stitches and backtack stitches.

*2 ... At the time of shipment from the factory, the maximum sewing speed is set to 4,500 rpm. If you would like to sew at speeds higher than this, change the setting of the DIP switch inside the control box.

Furthermore, the maximum sewing speed may be limited by the type of sewing pattern and the zigzag width.

*3 ... The maximum number of custom-made patterns that can be stored is 99 patterns with a total of 10,000 stitches, at 500 stitches or less per pattern.

*4 ... If you would like to reduce the pressure of the presser foot (such as when sewing light-weight materials), replace the compression spring with the accessory spring.

*5 ... At the time of shipment from the factory, the trimming margin is set to 2--6.5 mm. The trimming margin may be limited by the zigzag width and gauge part size.

Machine body

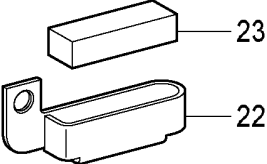
" OPTION PARTS "			
			
REF.NO	CODE	Q'TY	NAME OF PARTS
			<OPTION PARTS>
22	S51814001	1	THREAD GUIDE, F
23	114941001	1	FELT

Threading mechanism

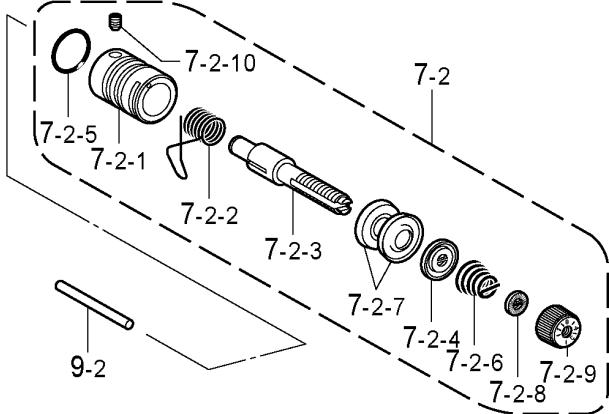
" OPTION PARTS "			
			
REF.NO	CODE	Q'TY	NAME OF PARTS
			<OPTION PARTS>
			<For rock stitchers>
7-2	S51808001	1	THREAD TENSION ASSY
7-2-1	S48084001	1	THREAD TENSION BRACKET
7-2-2	S02620001	1	THREAD TAKE-UP SPRING
7-2-3	116922001	1	TENSION STUD
7-2-4	159805001	1	DISC PRESSER, ;TENSION
7-2-5	081014870	1	O RING, S14
7-2-6	104525001	1	SPRING, TENSION ;M
7-2-7	145446001	2	DISC, TENSION
7-2-8	S12441001	1	WASHER
7-2-9	S31032001	1	TENSION NUT
7-2-10	100402004	1	SET SCREW, SM3.57
9-2	S51809000	1	TENSION RELEASE PIN (26.2mm)

Edge trimmer mechanis

" OPTION PARTS "			
(Minimum trimming margin 1.5mm)			
			
REF.NO	CODE	Q'TY	NAME OF PARTS
36	S56098001	1	EDGE KNIFE
			<For "Minimum trimming margin 2mm">
38-1	S56099001	1	FIXED EDGE KNIFE
			<OPTION PARTS>
			<For "Minimum trimming margin 1.5mm">
38-2	S56360001	1	FIXED EDGE KNIFE

Rotary hook mechanism

< For "8570" >

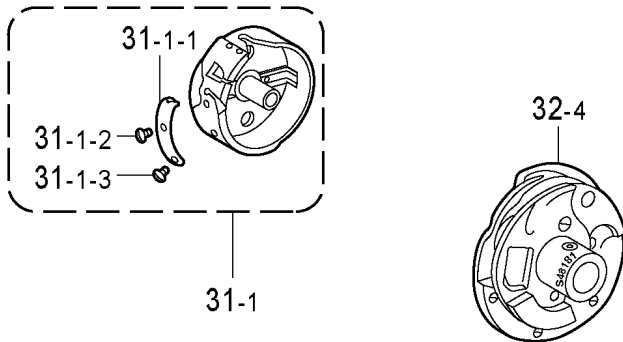

< For "8580" >

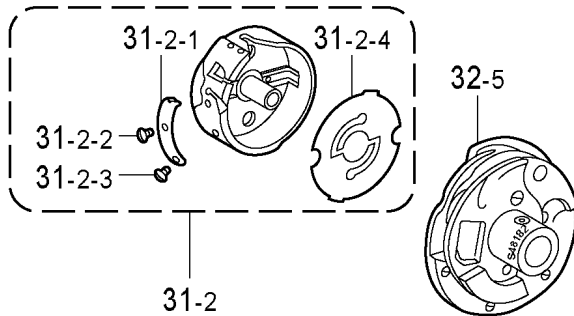

" OPTION PARTS "

- 32-9 (HP: 8570)
- 32-10 (HP: 8580)
- 32-13 (For medium materials: 8570)
- 32-14 (For medium materials: 8580)
- 32-17 (For light or coarse materials: 8570)
- 32-18 (For light or coarse materials: 8580)

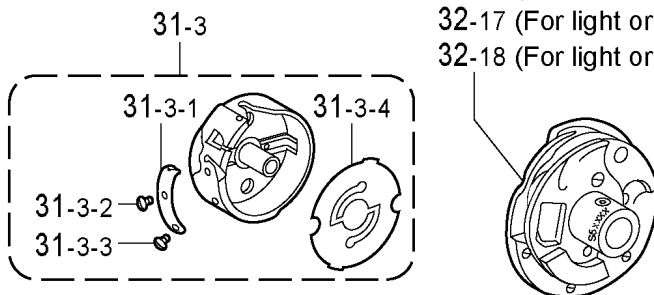

Rotary hook mechanism

REF.NO	CODE	Q'TY	NAME OF PARTS
			<For "8570">
31-1	S48180001	1	BOBBIN CASE ASSY
31-1-1	S09477001	1	SPRING
31-1-2	180721001	1	SCREW
31-1-3	183507001	1	ADJUSTING SCREW
			<For "8580">
31-2	S48202001	1	BOBBIN CASE ASSY
31-2-1	S09477001	1	SPRING
31-2-2	180721001	1	SCREW
31-2-3	183507001	1	ADJUSTING SCREW
31-2-4	S48203001	1	SPRING, ANTI-SPIN
			<OPTION PARTS>
31-3	S48378001	1	BOBBIN CASE ASSY
31-3-1	S09477001	1	SPRING
31-3-2	180721001	1	SCREW
31-3-3	183507001	1	ADJUSTING SCREW
31-3-4	S48203001	1	SPRING, ANTI-SPIN
			<For "8570">
32-4	S48181901	1	ROTARY HOOK ASSY, W/BOX ;ST
			<For "8580">
32-5	S48182901	1	ROTARY HOOK ASSY, W/BOX ;TR
			<OPTION PARTS>
			<Carbide tip type>
			<For "8570">
32-9	S51821901	1	ROTARY HOOK ASSY, HP W/BOX
			<For "8580">
32-10	S51822901	1	ROTARY HOOK ASSY, HP W/BOX
			<For medium materials>
			<For "8570">
32-13	S55026901	1	ROTARY HOOK ASSY, W/BOX ;ST
			<For "8580">
32-14	S55027901	1	ROTARY HOOK ASSY, W/BOX ;TR
			<For light or coarse materials>
			<For "8570">
32-17	S58671901	1	ROTARY HOOK ASSY, W/BOX ;ST
			<For "8580">
32-18	S57929901	1	ROTARY HOOK ASSY, W/BOX ;TR

Presser foot lifting solenoid set (8580 Option parts)

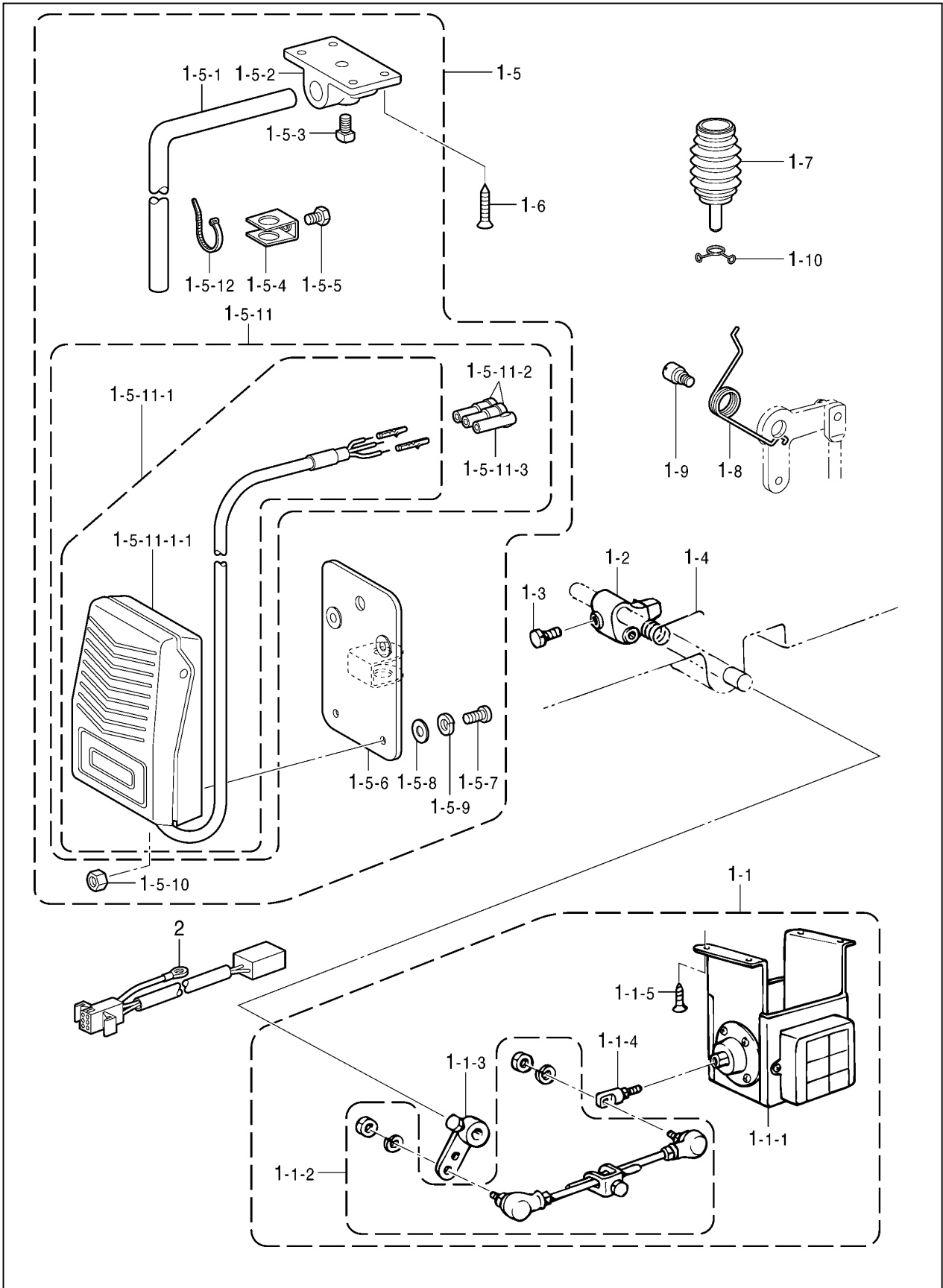

From the library of: Diamond Needle Corp

Presser foot lifting solenoid set (8580 Option parts)

REF.NO	CODE	Q'TY	NAME OF PARTS
			<For Japan only>
1	183969001	1	-----
1-1	183961151	1	-----
1-1-1	S42963051	1	P-FOOT LIFTER SOLENOID ASSY
			<For export>
1	183967001	1	P-FOOT LIFTER SOLENOID SET, 1D
1-1	183962151	1	P-FOOT LIFTER SOLENOID SET, 4
1-1-1	S42197051	1	P-FOOT LIFTER SOLENOID ASSY
1-1-2	S42198051	1	PRESSER FOOT LIFTER ROD ASSY
1-1-3	S42199051	1	P-FOOT LIFTER LEVER ASSY
1-1-4	S41955051	1	ROD JOINT ASSY
1-1-5	S42200051	4	WOOD SCREW
1-2	S02595101	1	PRESSER FOOT LIFTER LINK
1-3	146367001	1	BOLT, SM5.95
1-4	S02596001	1	SPRING, TWIST
1-7	S16250001	1	KNEE LIFTER COMPLYING BAR ASSY
1-8	154347001	1	SPRING
1-9	S31010001	1	SHOULDER SCREW, SM6.35
1-10	S07015001	1	CLIP
			<For Japan only>
1	183970001	1	-----
1-1	183961151	1	-----
1-1-1	S42963051	1	-----
1-1-2	S42198051	1	-----
1-1-3	S42199051	1	-----
1-1-4	S41955051	1	-----
1-1-5	S42200051	4	-----
1-2	S02595101	1	-----
1-3	146367001	1	-----
1-4	S02596001	1	-----
1-5	S07045009	1	-----
1-5-1	142026003	1	-----
1-5-2	142027001	1	-----
1-5-3	100463001	1	-----
1-5-4	114967001	1	-----
1-5-5	110087001	1	-----
1-5-6	S07027001	1	-----
1-5-7	062401006	4	-----
1-5-8	025040233	4	-----
1-5-9	028040243	4	-----
1-5-10	021400164	4	-----
1-5-11	S07030009	1	-----
1-5-11-1	S07031009	1	-----
1-5-11-1-1	S07032009	1	-----
1-5-11-2	146046000	2	-----
1-5-11-3	146194000	1	-----
1-5-12	149799000	1	-----
1-6	034422503	4	-----
1-7	S16250001	1	-----
1-8	154347001	1	-----
1-9	S31010001	1	-----
1-10	S07015001	1	-----
			<Common parts>
2	S47686000	1	RELAY HARNESS

Attachment set (Option parts)

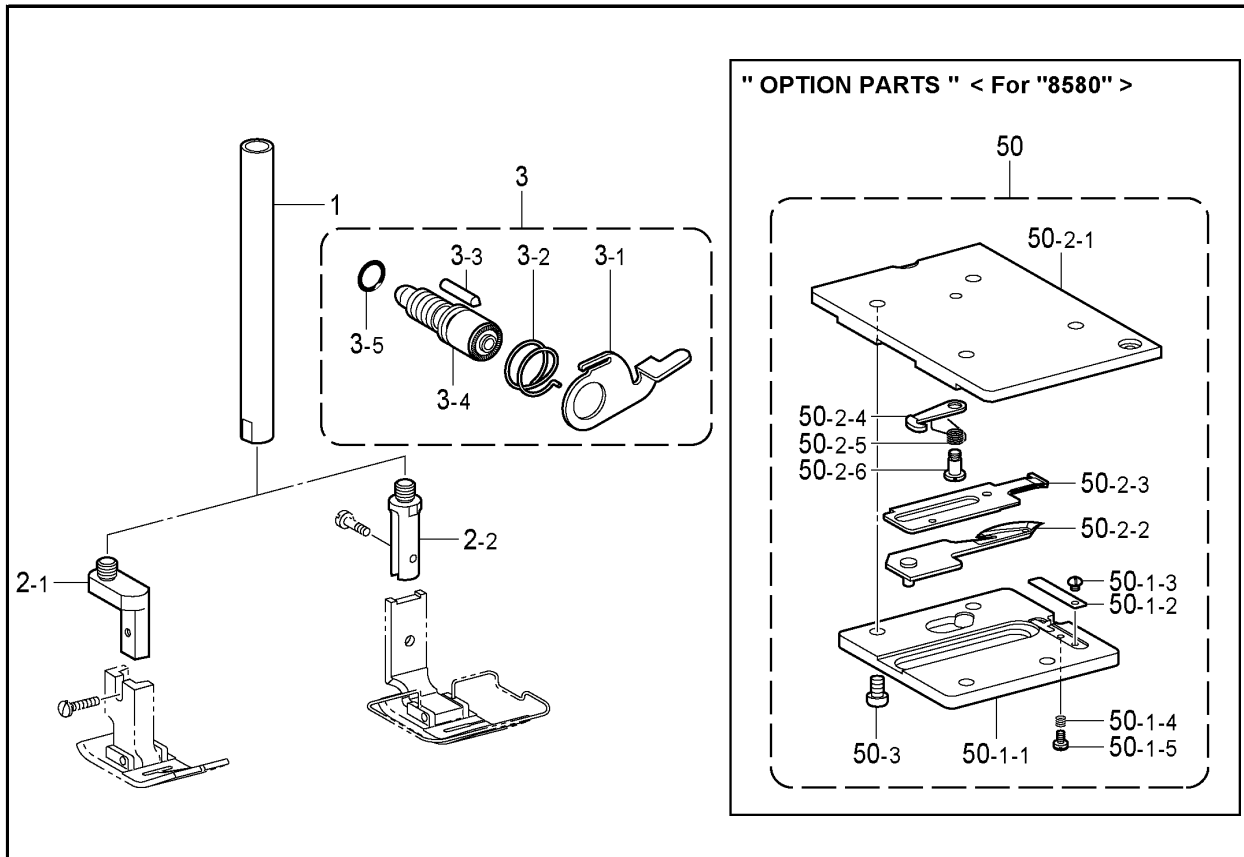

REF.NO	CODE	Q'TY	NAME OF PARTS
1	S50114001	1	PRESSER BAR, U
2-1	S50115001	1	PRESSER BAR TIP, A
2-2	S50116001	1	PRESSER BAR TIP, B
3	S80017101	1	DIAL LOCK LEVER SET
3-1	S39829101	1	DIAL LOCK LEVER
3-2	S39830101	1	SPRING
3-3	S50098001	1	POSITINING PIN
3-4	S50099001	1	ADJUSTING SCREW
3-5	108549001	1	O RING
			<Option parts for 8580>
50	S51419201	1	KNIFE UNIT, T
50-1-1	S48238001	1	KNIFE HOLDER
50-1-2	S48239001	1	SPRING, LOWER THREAD PRESSER
50-1-3	100105005	1	SCREW, SM2.38X2.4
50-1-4	S48240001	1	ADJUSTING SPRING
50-1-5	S48247001	1	SCREW, SM2.38X5
50-2-1	S48242001	1	KNIFE BRACKET
50-2-2	S55866001	1	MOVEABLE KNIFE, T <Marked in "T">
50-2-3	S55864001	1	FIXED KNIFE
50-2-4	S55865001	1	CLUTCH, FIXED KNIFE
50-2-5	S48246001	1	SPRING, CLUTCH
50-2-6	155103001	1	SHOULDER SCREW, SM3.18
50-3	062670712	4	SCREW, PAN SM3.57-40X7

Gauge parts list

The * symbol is for standard parts.

Zigzag width	Needle plate	Feed dog	Presser foot assy	Stopper
7.5mm (Minimum trimming margin 2mm)	S56085-001 	S56097-001 	S56093-001 	S56363-000 (Black color)
8mm (Minimum trimming margin 1.5mm)				S48073-000 Option (White color)
4.5mm (Minimum trimming margin 2mm)	* S56084-001 	* S56096-001 	* S56091-001 	*S56362-000 (Black color)
5mm (Minimum trimming margin 1.5mm)				S56039-000 Option (White color)
2.5mm (Minimum trimming margin 2mm)	S56083-001 	S56095-001 	S56086-001 	S56361-000 (Black color)
3mm (Minimum trimming margin 1.5mm)				S56040-000 Option (White color)